

BCL

Single Point Load Cell, 60kgf-200kgf

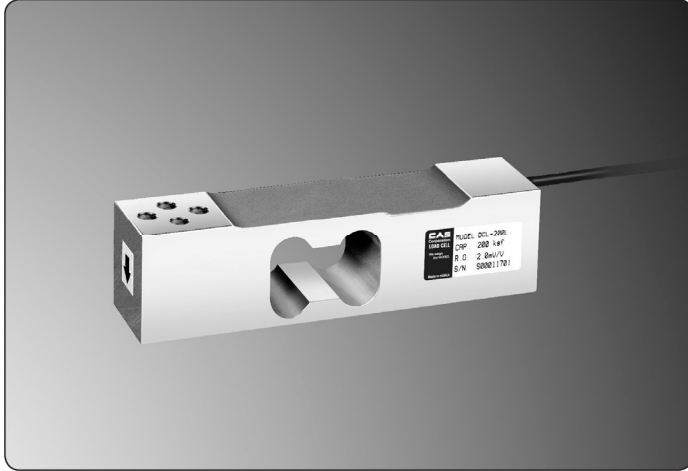

LOAD CELL



DIMENSION

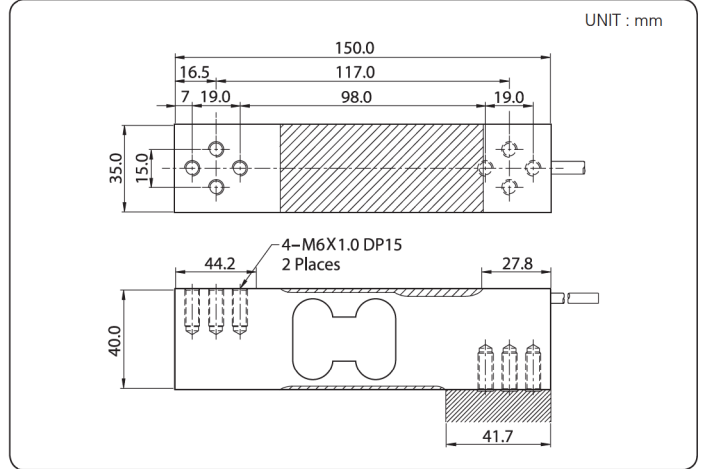

FEATURES

- Off center compensated
- Low profile & easy installation
- Anodized aluminum construction
- Designed according to IP65

SPECIFICATION

Capacity		kgf	60, 100, 150, 200
Rated Output		mV / V	2.0 ± 0.2
Zero Balance		mV / V	0.0 ± 10.1
Accuracy Class		-	-
Non-Linearity		% R.O.	≤ 0.03
Hysteresis		% R.O.	≤ 0.03
Combined Error		% R.O.	≤ 0.03
Repeatability		% R.O.	≤ 0.01
Creep for 30min.		% R.O.	≤ 0.03
Return for 30min.		% R.O.	≤ 0.03
Resolution		-	≤ 1/3000
Division		mV / V	0.00067
Temperature Effect on	-Zero Value	%/10°C	≤ 0.028
	-Output Value	%/10°C	≤ 0.014
Excitation	-Recommended	V	10
	-Maximum	V	15
Resistance	-Input	Ω	420 ± 20
	-Output	Ω	350 + 3.5
	-Insulation	MΩ	> 2000
Compensated Temperature Range		°C	- 10 to + 40
Operating Temperature Range		°C	- 20 to + 70
Material & Plate		-	Anodized Aluminum
Cable Specification		-	∅4 x 4P x 2M (P.V.C)
Safety Overload		% R.L.	150% R.L.
Platform Size		mm	400 x 400